

PASSENGER • Hospital

Single Jack Under Car • Front/Front & Rear Opening

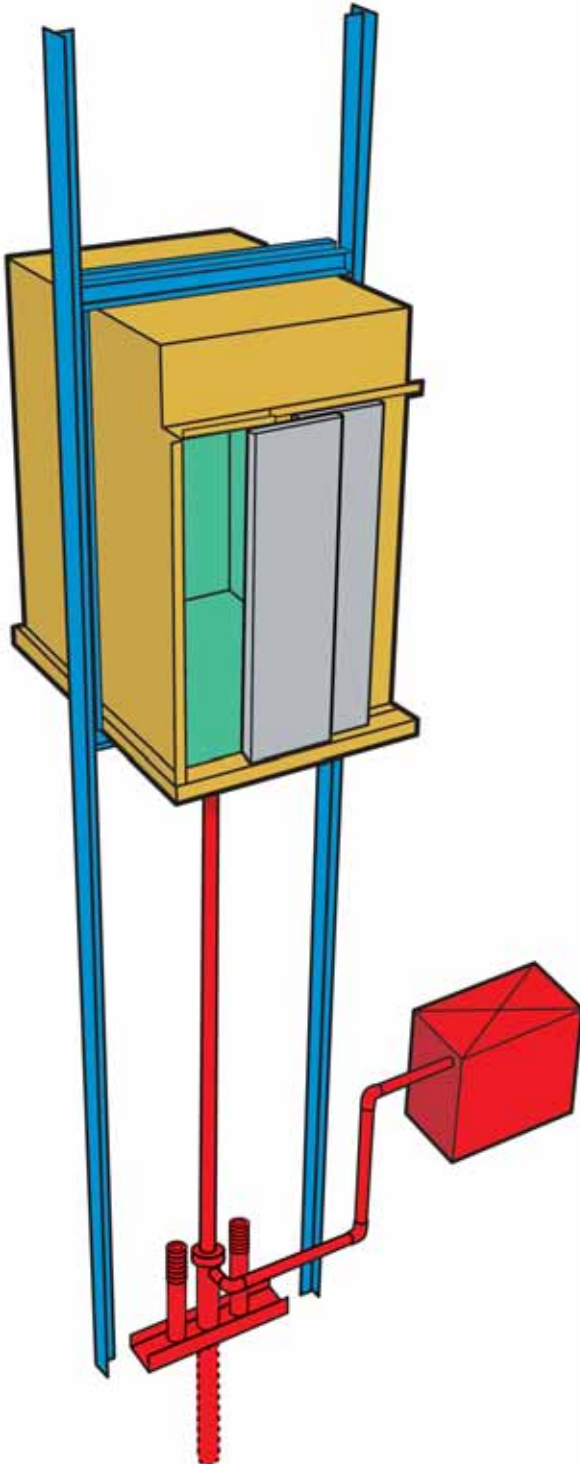

The very application demands critical performance and Canton Elevator responds with this highly reliable, smooth-operating hospital system. The design is configured primarily to accommodate stretcher beds including ample room for attendants. Additionally, these are multi-purpose elevators that can serve most every hospital, intermediate care and nursing home facility where both visitors and staff must use them. The cab provided in this series features a blend of handsome woodgrain laminate and rugged #4 brushed stainless steel, all of which can be very easily sanitized and maintained. They are available in 4000-lb. through 5000-lb. capacities with travels up to six floors or more. The system incorporates our advanced hydraulic jack technology and the highest quality machinery and support components. You can choose from a variety of entry treatments that permit you flexibility in coordinating with many decors and environs.

Like all Canton Elevator systems, all components incorporated in this series are unequalled for efficient, reliable operation. What's more, they provide a simplified service format that helps assure the owner of low-cost maintenance over the long term.



This information is intended for preliminary planning. We have attempted to include the basic data that you will require in your planning efforts. For details about specific or custom installations please contact your local Canton Elevator representative, or contact us directly.

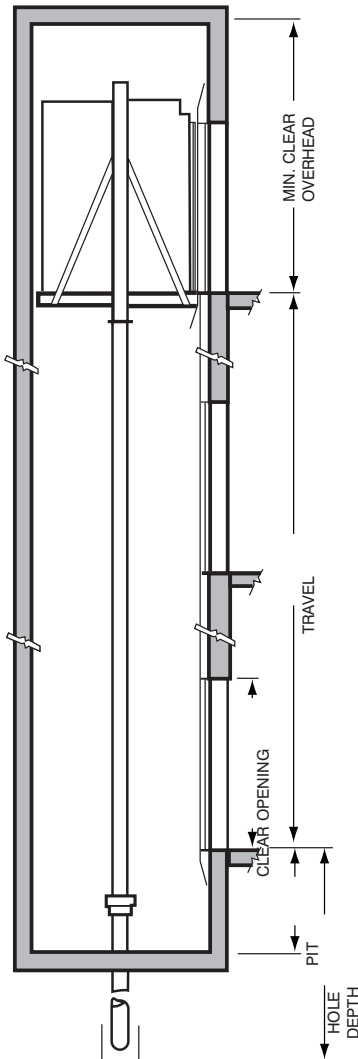

- Pit depth - 4'-0" min. is standard.
- Hole depth from lower terminal landing is approx. Travel + 6'-0".
- Min. clear overhead required (based on 8'-0" high cab):
For up to 100 FPM = 11'-10".
For 100 FPM and over = 12'-1".
If available overhead clearance is less than above, cab height can be reduced accordingly up to code minimum.
- Speeds available to 200 FPM.

NOTES:

1. Adequate supports for rail fastenings are required at all rail bracket locations (14' maximum spacing). Concrete or block walls (or steel or concrete beams) are recommended for support. Inserts should be furnished in block or brick walls. Blocks must be filled with mortar around inserts to provide rigid support.
2. Pit and overhead clearances shown are in accordance with ANSI code requirements.
3. A pit ladder (by others) is required if pit depth exceeds 36" (Rule 106.1d).
4. Leave 30" square hole in pit floor (see elevator contractor representative for location) for jack unit installation. Hole to be grouted in by others after jack unit is set in place.
5. Top of hatch must be vented in accordance with building codes.
6. A 110V outlet is required in the pit.
7. Hoist beam to be removed by others after elevator installation, if minimum cab clearance is not available.

MACHINE ROOM

1. An area of 5'-6" x 7'-0" x 8'-0" high is usually adequate for single car installations, with 3'-0" wide door opening for access.
2. Recommended location is adjacent to elevator hoistway at lowest landing; however, it can be remotely located - and at any level - if necessary.
3. Adequate heating and ventilation to meet code requirements must be provided.

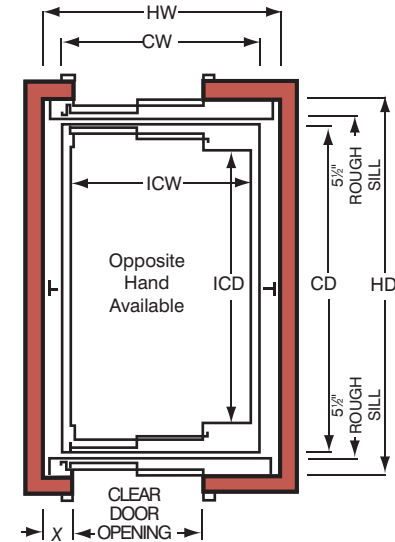
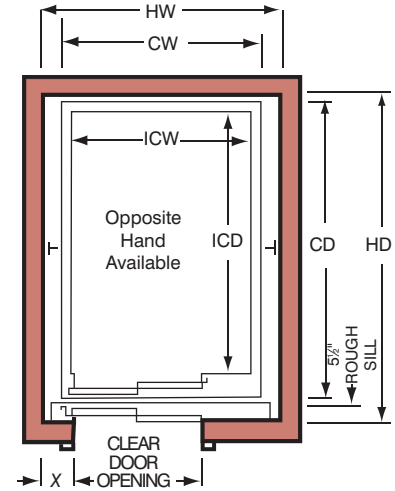

FRONT OPENING ONLY

DIMENSIONS	CAPACITY		
	4000#	4500#	5000#
HW	7'-4"	7'-4"	8'-1"
HD	9'-6"	9'-11"	10'-5"
CW	6'-0"	6'-0"	6'-0"
CD	8'-8"	9'-1"	9'-7"
ICW	5'-8"	5'-8"	5'-8"
ICD	7'-8"	8'-1"	8'-7"
X	11"	11"	13"
CLEAR DOOR OPENING	4'-0"	4'-0"	4'-6"

FRONT AND REAR OPENING

DIMENSIONS	CAPACITY		
	4000#	4500#	5000#
HW	7'-4"	7'-4"	8'-1"
HD	10'-7½"	11'-0½"	11'-6½"
CW	6'-0"	6'-0"	6'-0"
CD	9'-4"	9'-9"	10'-3"
ICW	5'-8"	5'-8"	5'-8"
ICD	7'-8"	8'-1"	8'-7"
X	11"	11"	13"
CLEAR DOOR OPENING	4'-0"	4'-0"	4'-6"

* All cars comply with NEII recommendations for minimum handicap size.



2575 GREENSBURG ROAD • NORTH CANTON, OH 44720 • PH. 330-833-3600 FAX 330-833-0229

E-Mail info@CantonElevator.com

VISIT OUR WEB SITE

<http://www.CantonElevator.com>